



PS AUDIO®

Owner's Reference



aspen

FR5 LOUDSPEAKER



Table of Contents

Aspen® FR5

Safety Information	1
Introduction	2
Unpacking FR5	3
Assembling the Stand	4-6
Wiring FR5	7
Basic Setup and Placement	8-9
Specifications	10
Warranty Information	11-12
Service Information	13-14



Safety Information

Aspen® FR5

Important Safety
Instructions



READ AND FOLLOW ALL INSTRUCTIONS
HEED ALL WARNINGS



MAGNETIC FIELD

As with most loudspeakers, the FR5 uses strong magnets in the drivers. People with implanted medical devices should use caution around the speaker. Magnetic fields of 5G can be present up to 18" (50 cm) from certain parts of the speaker.

DO NOT EXPOSE THIS APPARATUS TO RAIN OR MOISTURE. OBJECTS FILLED WITH LIQUIDS, SUCH AS VASES, SHOULD NOT BE PLACED ON THE APPARATUS.

Clean only with a dry cloth. Do not place flammable material on top of or beneath the unit.

Turn off all systems' power before connecting the PS Audio® component to any other component. Make sure all cable terminations are of the highest quality.

THERE ARE NO USER-SERVICEABLE PARTS INSIDE THIS PS AUDIO PRODUCT. REFER ALL SERVICE NEEDS TO QUALIFIED SERVICE PERSONNEL.

Please contact your authorized dealer, distributor, or PS Audio® directly if you have any questions or concerns that are not addressed in this reference manual. PS Audio® and the sine wave logo are registered trademarks of PS Audio, Inc., and are restricted for use to PS Audio, Inc., its subsidiaries, and authorized agents.

This product was designed in Boulder, Colorado.

© 2024 PS Audio, Inc. All rights reserved. Rev. C



Introduction

Aspen® FR5

Thank You

Thank you for your purchase of the PS Audio Aspen FR5 Loudspeaker. This is your comprehensive Operator's Guide, intended to provide a full overview of the Aspen FR5's functions and capabilities. It is our intention to answer any and all questions you may have in this manual. If you have additional questions or concerns that are not addressed in this guide, please contact us and we will be happy to assist you.

Contact Information

PS Audio, Inc.
4865 Sterling Drive
Boulder, CO 80301
1 (800) PSAUDIO
service@psaudio.com
www.psaudio.com

A Message From The Design Engineer

After nearly 50 years in business and many years in development, PS Audio is proud to present the Aspen Series Loudspeakers. The FR5 is an elegant 2-way standmount speaker that is a modern take on our favorite planar magnetic hybrid loudspeakers of the past. The FR5's clarity and detail make the most of high-resolution recordings while providing the musicality and power that you'd expect from PS Audio.

The Aspen Series incorporates much of what we have learned as a company about design and manufacturing as we pursue our ultimate sonic vision: to offer a complete end-to-end system. On a personal level, it has been a dream project to put what I've learned throughout my career into a reference product for your musical enjoyment.

Chris Brunhaver
Senior Speaker Design Engineer



Getting Started

Aspen[®] FR5

Included with the aspen FR5

2 speaker enclosures in cloth bag

2 cloth magnetic grilles

Accessories also include this owner's manual, jumpers (for configuring the inputs for mono or bi-wiring), and 8 adhesive rubber feet.

Note: Only apply the rubber feet to the bottom of the speaker if not using the PS Audio stand. (If using the stand, rubber feet will be installed on the stand.)

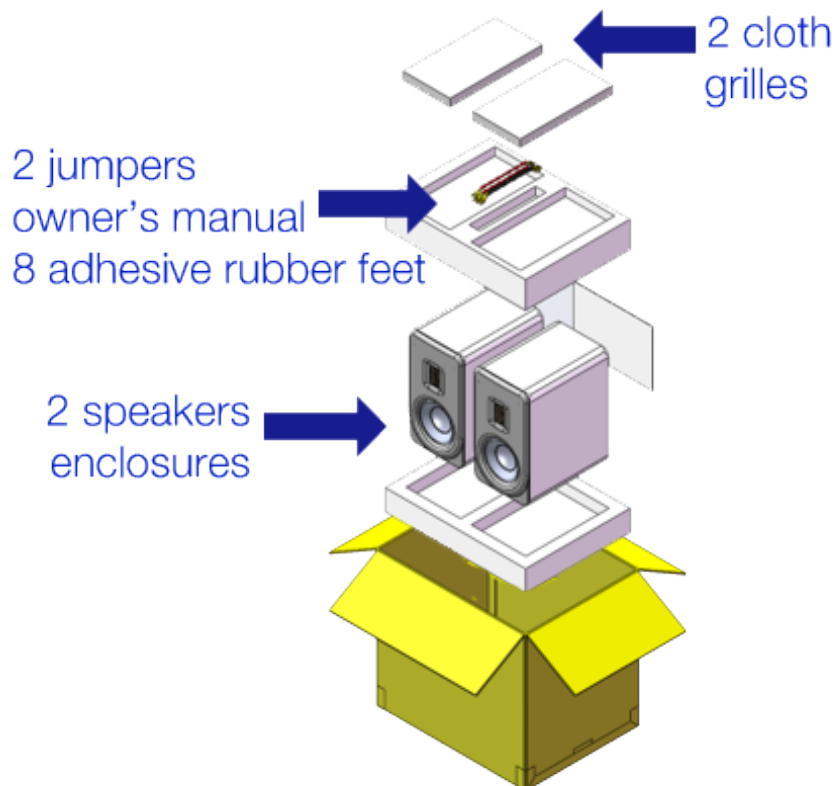



Getting Started

Aspen® FR5

Assemble Stand

If you purchased an FR5 stand with your speakers, see the below installation instructions. If you did not purchase the FR5 stand, go to page 7.

Stand Materials

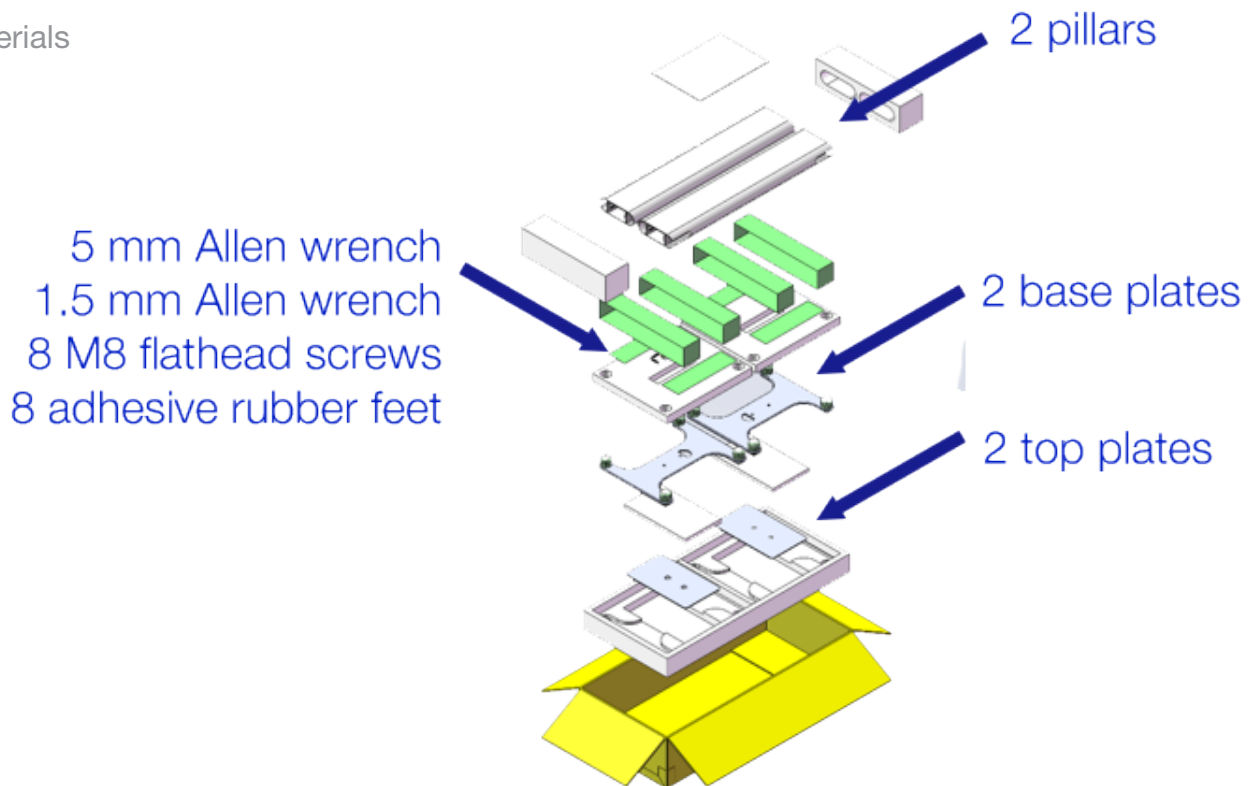

Configuring Stand Feet

The base plate has the 4 feet installed. Before assembling the stand, make adjustments to the feet.

For hard floors, remove the spiked tip. It is not meant for hardwood and could scratch your floor.

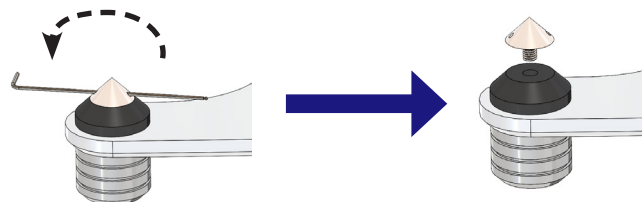

To remove the tip, put the small 1.5 mm Allen wrench through the two holes in the spiked tip. Use this as a lever to help twist off the bottom 0.375" spiked tip from each foot and expose the rubber foot underneath.



Getting Started

Aspen® FR5

Configuring Stand Feet

For carpeted floors, leave the spiked tip in place.

Leveling:

These are leveling feet as well. After assembling the stand, you can level the feet before placing the speaker on top. While small adjustments may be needed once the speaker is in place, adjusting the feet in advance will be easier.

To level the feet, start by loosening the top cap of the foot. Once it's loose, loosen the bottom of the foot until the stand is level. Tighten the top cap again to lock the foot in position.

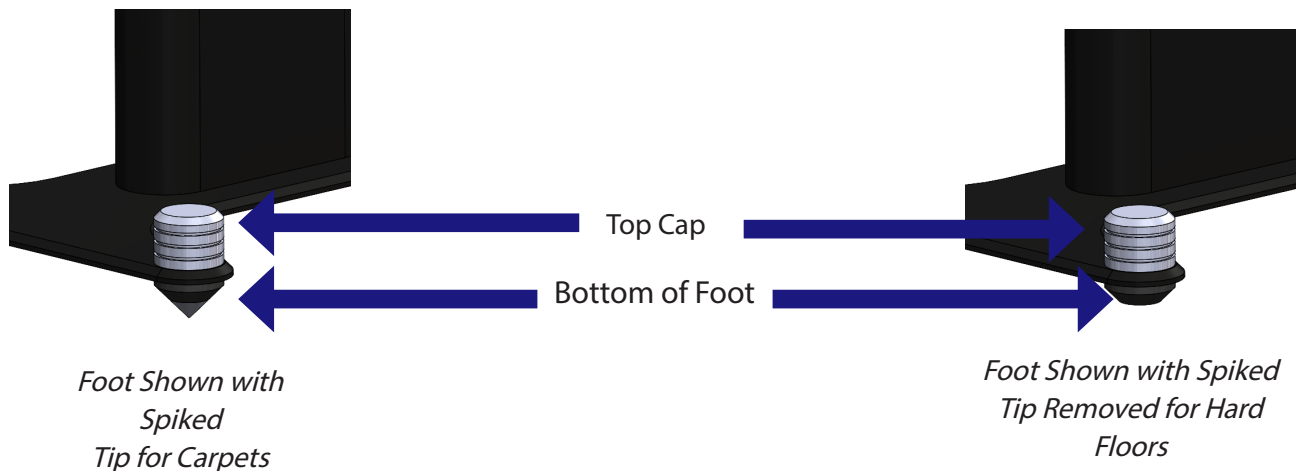

Note: Aftermarket isolation feet with a compatible M8 X 1.25 thread to screw into the aluminum base plate can also be used.



Getting Started

Aspen[®] FR5

Stand Assembly

Step 1: Attach base plate to pillar using 2 M8 screws.

Step 2: If desired, the front and middle channels of the pillar can be filled with sand, kitty litter, etc. to provide greater stability and better definition.

Front and Middle Channel

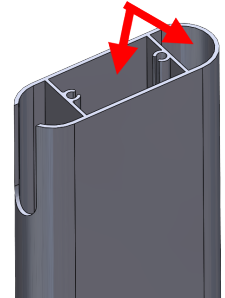

Step 3: Attach the top plate to the pillar using 2 M8 screws.

Note: The top plate can be oriented to either line up with the front of the base plate or the rear of the base plate.

Step 4: The channel at the rear of the pillar is for routing speaker cables. Before installing your speaker, feed the speaker cable up through the hole in the bottom of the pillar and out through the hole in the top. If the cables are small enough, they can be fed up through the hole in the base plate instead.

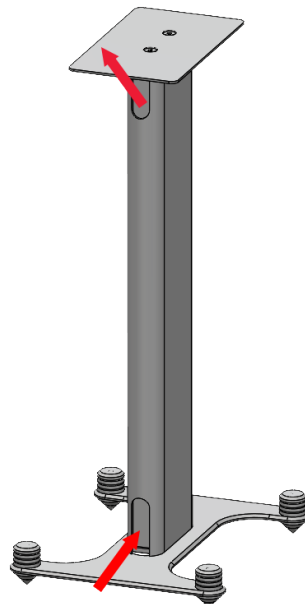
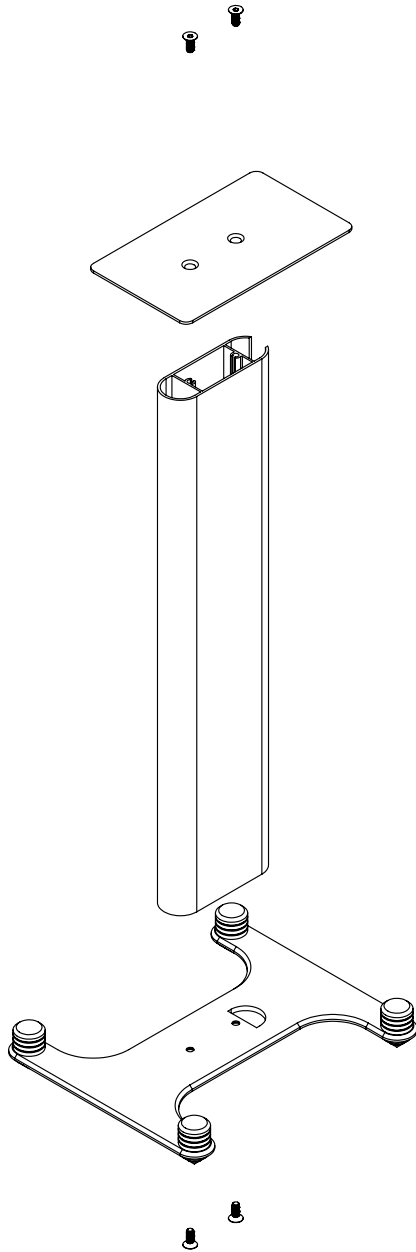

Cable Routing for Larger Cable

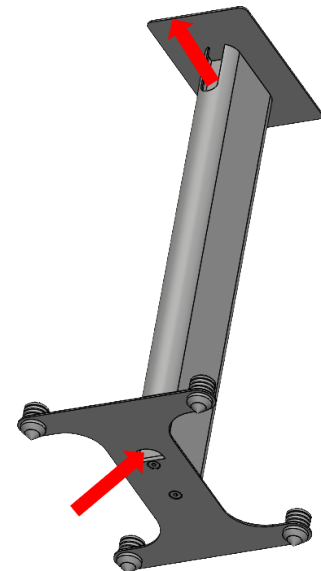

Cable Routing for Small Cable

Step 5: Install 4 rubber feet adhesive side down on the 4 corners of the top plate.

Step 6: Place speaker on top of the speaker stand.



Getting Started

Aspen[®] FR5

Jumper / Input
Wiring
(bi-amp, bi-wiring)

The FR5 comes with four input terminals as shown. For single wiring/amping, connect the set of jumpers from the accessory box to parallel wire the black and red terminals sets together (black to black and red to red) as shown below. Connect a single amplifier to the left set of terminals.

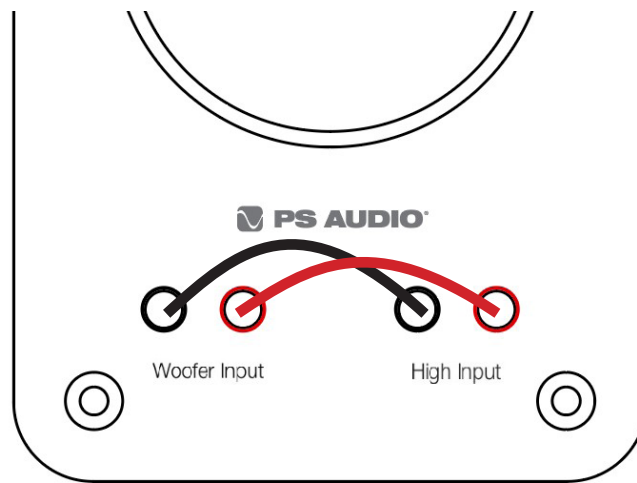

Note: Binding posts may have plugs. If using banana plugs, remove the plugs first.

For bi-wiring/bi-amping, do not connect the jumpers as shown below.

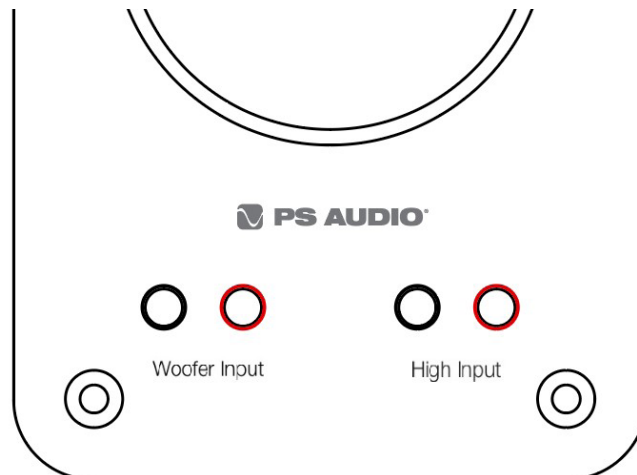



Speaker Placement

Aspen® FR5

Basic Setup and Placement

Loudspeakers and the room layout work together as a system. To get the best performance, it's important to take great care when setting up your speakers.

Some helpful tools include a tape measure (or laser measurement tool), pen/paper to note the distances and listening impressions, and some demo music.

Distances to sidewalls/front wall:

One of the most important aspects of speaker room placement is the speaker's distance from boundaries, such as large objects and walls. In particular, best performance is typically found when the speakers are a minimum of 3 ft from the side walls and placed symmetrically to each other (or very close to that). This distance minimizes early reflections off the wall from interfering with the tonality of the sound coming directly from the speaker.

If you are in a dedicated space where the speaker can be placed out into the room, the distance the speakers are from the front wall should be chosen through listening. In general, start by placing the speakers about 18 inches from the front wall. From there, listen to acoustic/vocal music with good bass and percussion and gradually inch the speakers away from the wall, assessing the sound as you go. (You want to make sure that the lower range voice and bass instruments are the most natural sounding and balanced with the midrange.) Keep inching both speakers into the room until the current position sounds worse than the previous position. Then move them back to the previous position where the tonal balance was the most natural.

Generally, moving speakers nearer the wall emphasizes the lower range of voices, so inching them away until voices no longer sound chesty is a good initial placement.

Speaker width and toe-in:

In general, your listening position should be about 20% outside of an equilateral triangle formed by the width of the speakers (+/- 30 degrees from center). For instance, if the listening position is 10 ft (~3 m) from the speakers, a starting width for the speakers should be ~8 ft (~2.4 m).

Placing the speakers closer together gives a bit less "width" to the sonic image but can give a stronger phantom center image and more warmth and bloom in the low midrange.



Speaker Placement

Aspen® FR5

The speakers should be toed-in a little, aimed at a point in space about 3 ft behind the listening position.

Further pointing of the speakers towards the listening position will increase “focus” and the level of the extreme treble at the expense of the spaciousness and “width” (perception of sound coming from outside the width of the speakers).

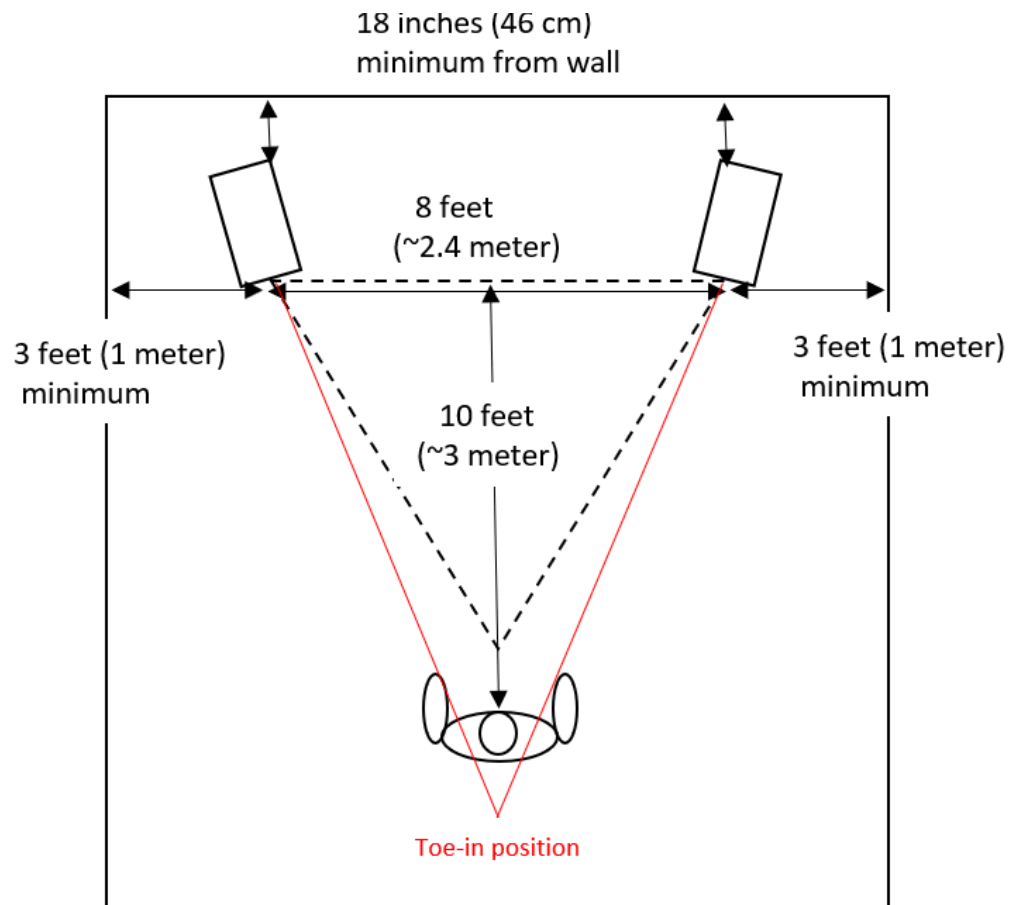

Diagram of initial speaker placement if listening position is 10 ft (~3 m) from speakers



Specifications

Aspen® FR5

Aspen FR5 Specifications

Color Options	Satin White, Satin Black
Enclosure Type	Passive radiator (one 6x9" oval rear-firing)
High Frequency Transducer	2.5" planar magnetic with Teonex diaphragm
Low Frequency Transducer	1 x 6.5" woofers, cast frame, Curv woven polypropylene, advanced magnet structure
Crossover Frequency	1750 Hz - Linkwitz-Riley 6th order acoustic
Sensitivity (2.83V @ 1M)	83.5 dB
Nominal Impedance	6 ohm (5.6 ohm minimum impedance)
Recommended Amplifier Power	50-150 W
Frequency Response	35 Hz-20 kHz (-6dB) half space, 30 Hz (-6 dB) in-room
Dimensions (HxWxD)	14.5" x 8" x 13" speaker only (with binding posts) 28.25"x11.75"x14" stand only
Net Weight	Speaker: 26.6 lbs (12.1 kg) each Stand: 13.7 lb (6.2 kg) each



Warranty Information

Aspen® FR5

Registering Your Product

By registering your product, you are validating the start date of your limited warranty. This limited warranty is in effect for 3 years from the date the unit was first purchased from PS Audio or its dealers and agents. If you do not register your product within 30 days of service, a copy of your purchase receipt from an authorized PS Audio dealer may be used as proof of purchase to establish the warranty start date. If no proof of purchase from an authorized PS audio dealer or registration is provided, the production date of the product will be used to determine the warranty start date. You can register your product online, by phone, by mail, or by email.

What This Warranty Covers

This warranty covers defects in material and workmanship for products purchased from PS Audio or its authorized dealers and agents. In the event your product fails, your sole remedy under this limited warranty shall be to return the product to PS Audio or an authorized PS Audio repair center. At the option of PS Audio, the product will be repaired without charge for parts or labor, replaced, or the purchase price refunded through the original point of purchase.

Shipping

You are responsible to pay for the safe and proper shipment of the warranted product to PS Audio or its authorized repair center. Under this limited warranty, PS Audio or its authorized repair center will pay the cost of returning the repaired or replacement product to you.

What This Warranty Does Not Cover

This warranty does not cover damage due to:

- Accidents, carelessness, improper transportation, misuse, neglect, or abuse
- Failure to follow the operating instructions that are provided by PS Audio in the Owner's Reference Manual (available for download at www.psaudio.com)
- Use in any manner inconsistent with PS Audio's operating instructions (available for download at www.psaudio.com)
- Lack of routine maintenance
- Connection to an improper voltage supply
- Alterations or modifications to the unit
- Improper or unauthorized repair, including repairs not authorized by PS Audio or a PS Audio authorized repair center
- Fire, lightning, flood, "Acts of God," or other contingencies beyond the control of PS Audio
- Products purchased through an unauthorized source (if you have questions as to whether or not a dealer is authorized, please contact customer support at www.psaudio.com)
- Products with a factory-applied serial number that has in any way been altered, defaced, or removed



Warranty Information

Aspen® FR5

Limitations Under This Warranty

In no event will PS Audio's liability to you exceed the original purchase price of your unit. This warranty does not cover the cost of custom installation, customer instruction, setup adjustments, or signal reception problems. Consequential and incidental damages are not covered under this warranty. However, some states do not allow the exclusion or limitation of incidental or consequential damages, so this limitation or exclusion may not apply to you. In the event that your warranted product cannot be repaired, PS Audio will either replace or refund the cost of the unit. We reserve the right to replace any out-of-stock, discontinued, or limited edition products with a comparable product. Discontinued products may not be available for warranty replacement.

Warranty Transfer

This warranty is for the benefit of the original purchaser of the product. The warranty may be transferred to a subsequent purchaser during the 3 year warranty period. To do this, you must contact PS Audio directly to set up a transfer of warranty registration.



Service Information

Aspen® FR5

Warranty Service Within North America

Please contact PS Audio customer support for service assistance, help with locating an authorized PS Audio repair center, help with the operation of a product, or for more information.

Obtaining An RMA#

In order to receive warranty service, you must first obtain a Return Merchandise Authorization Number (RMA#) prior to returning any item. Please contact PS Audio or an authorized PS Audio repair center to receive an RMA#. The RMA# must be on all returned items. If it is not clearly marked, PS Audio will return the package back to you, freight collect.

Packaging and Shipping

Original packaging should be used for the safe transit of your PS Audio unit to the repair center. If you do not have the original packaging, PS Audio can sell and ship replacement packaging to you. You are responsible for the cost of shipping the product to a PS Audio authorized repair center. You should insure the product for its full retail cost, in the event it gets lost or damaged in transit. PS Audio is not responsible for damage incurred during the transit of products sent to us. Shipping your product in non-PS Audio packaging may void this warranty. PS Audio reserves the right to charge you for new factory packaging to return your product after a repair.

State Law

This warranty gives you specific legal rights. You may also have other rights, which vary from state to state.

International Warranty Service

PS Audio has authorized distribution in many countries of the world. In each country, the authorized importing distributor has accepted the responsibility for warranty of the products sold by that distributor. Warranty service should be obtained where the product was purchased.

Changes To Our Products

PS Audio reserves the right to modify the design of any product without obligation to purchasers of previously manufactured products, and to change the prices or specifications of any products without notice or obligation to any person.



Your Product

Aspen® FR5

Your Serial
Number

Your Purchase
Information

Date of Purchase



Notes

Aspen® FR5



Notes

Aspen® FR5



At PS Audio, we're family.

Not just a family that runs in bloodlines, but in frequencies.

Because while we may not all share the same genes here, we are all related by a passion, nay, obsession with listening to the music we love at the highest, most breathtaking quality possible.

And in our minds, that makes us kin.

In fact, we believe that every nutty, hertz-counting audiophile out there is part of our tribe.

That's how we've built our company over the last 50 years - with the kind of care and respect that you give to your family.